



Temperature Module Quick Start Guide

Basic Setup Steps:

- (1) Connect unit to power and network.
- (2) Set up a computer on the same network as the input module. To do this, set the IP address of the computer to 192.168.1.50 with a netmask of 255.255.255.0.
- (3) Configure the Temperature Module using web browser. Do this by pointing browser to <http://192.168.1.2/setup.html>. Password is webrelay (all lower case).
- (4) Set the permanent IP address in the configuration page. Restart the input module (remove power, re-apply power). After restarting the Temperature Module, set your computer back to it's original settings and access the input module at its new IP address.

Factory Default Settings

IP Address: 192.168.1.2
 Subnet Mask: 255.255.255.0
 Control Web Address: <http://192.168.1.2>
 Setup Web Address: <http://192.168.1.2/setup.html>
 Username: *no username required*
 Control Password: *no password set*
 Setup Password: webrelay (all lower case)

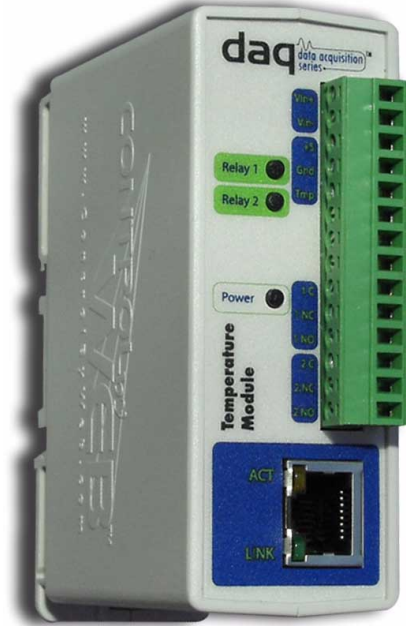

Pinout

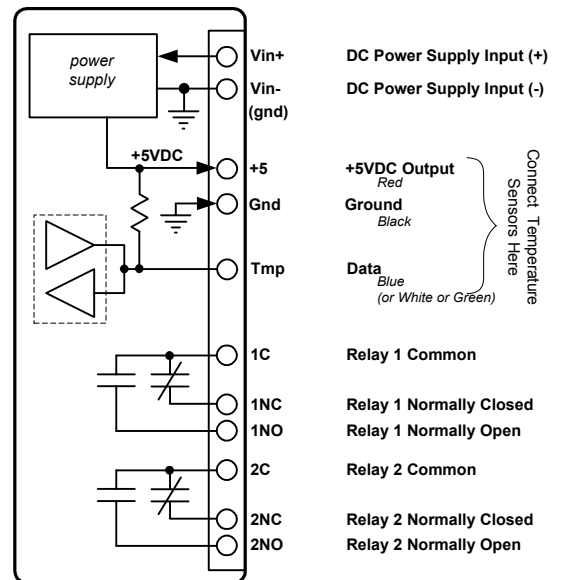

Note: The Temperature Module can be configured to operate at 10Mbps or 100Mbps. For best power savings and long term performance the 10Mbps setting is recommended.

Full Users Manual may be downloaded from <http://www.ControlByWeb.com>

For technical support, email questions to support@ControlByWeb.com



a division of...
 Xytronix Research & Design, Inc.
 North Logan, Utah, USA